

CENTRAL UNIVERSITY OF PUNJAB

Established vide Act No. 25 (2009) of Parliament

Tender No.: P-11(2015-16)



**Tender Notice for Purchase of Furniture items for Hostels
(BED/ CHAIRS/ STUDY TABLE/ STEEL ALMIRAH/ MATTRESSES/ BOOK RACKS/
CANTEEN CHAIR/ CANTEEN TABLE)**

(Two Bid System)

Release Date : June 13, 2015

Last Date : June 26, 2015; 11:00A.M.

City Campus, Mansa Road, Bathinda- 151001,
E-mail: registrar@cup.ac.in, Tel: 0164-2864155,

Central University of Punjab, Bathinda

Central University of Punjab invites sealed item wise tenders from Reputed Manufacturers Recognized/Authorized/Registered with any State/Central/UT Govt. Agency or Authorized Dealers of well-known reputed, branded Manufacturer for supply of Furniture items viz. Bed/ Chairs/ Study Table/ Steel Almirah/ Mattresses/ Book Racks/Canteen Chair/ Canteen Table. Documents in this respect must be attached.

| | | |
|---|---|---|
| Tender Notice Number | : | P-11(2015-16) |
| Release Date of the Tender | : | June 13, 2015 |
| Last date for the submission of Tender | : | June 26, 2015; 11:00 A.M. |
| Opening date of Tender | : | June 26, 2015; 01:00 P.M. (In case tender opening day declared holiday for any reason the tender will be opened on next working day at same time.) |
| Name and Address of the University | : | Registrar, Central University of Punjab, City Campus, Mansa Road, Bathinda – 151001, Punjab, India. |
| Tel. | : | 0164-2864155 |
| E-Mail Address | : | registrar@cup.ac.in |

| Sl. No. | Items | Qty. Required | Tender Fee (Rs.) | EMD(Rs.) |
|---------|---------------|---------------|------------------|----------|
| 1 | Beds | 200 Nos. | 200 | 8000 |
| 2 | Chairs | 200 Nos. | 200 | 8000 |
| 3 | Study Tables | 200 Nos. | 200 | 12000 |
| 4 | Steel Almirah | 200 Nos. | 200 | 26000 |
| 5 | Mattresses | 200 Nos. | 200 | 8000 |
| 6 | Book Racks | 200 Nos. | 200 | 16000 |
| 7 | Canteen Chair | 150 Nos. | 200 | 8000 |
| 8 | Canteen Table | 40 Nos. | 200 | 4000 |

Tender Fee and EMD drawn in favour of **Central University of Punjab, Bathinda** in the shape of Demand Draft only.

Note: 1. Please submit separate tender for each item. For example, if manufacturers/supplier has to quote bed and Chair, there will be totally separate tender along with all documents, EMD & Fee separately for each item. Top of the tender should be superscripted as “Tender for the item _____”.

2. **Sample of the item(s) to be supplied within 7 days by the technically eligible bidders for approval before opening of Price Bids. Shortlisted firms will be intimated for supply of samples accordingly.**

INDEX

| Sr. No. | Contents | Annexures |
|----------------|--|------------------|
| I. | GUIDELINES FOR PREPARATION OF TENDER | Annexure-A |
| II. | GENERALFINANCIAL TERMS AND OTHER CONDITIONS | Annexure-B |
| III. | TECHNICAL SPECIFICATIONS AND COMPLIANCE SHEET OF BEDS | Annexure-C |
| IV. | TECHNICAL SPECIFICATIONS AND COMPLIANCE SHEET OF CHAIRS | Annexure-D |
| V. | TECHNICAL SPECIFICATIONS AND COMPLIANCE SHEET OF STUDY TABLE | Annexure-E |
| VI. | TECHNICAL SPECIFICATIONS AND COMPLIANCE SHEET OF STEEL ALMIRAH | Annexure-F |
| VII. | TECHNICAL SPECIFICATIONS AND COMPLIANCE SHEET OF MATTRESSES | Annexure-G |
| VIII. | TECHNICAL SPECIFICATIONS AND COMPLIANCE SHEET OF BOOK RACKS | Annexure-H |
| IX. | TECHNICAL SPECIFICATIONS AND COMPLIANCE SHEET OF CANTEEN CHAIR | Annexure-I |
| X. | TECHNICAL SPECIFICATIONS AND COMPLIANCE SHEET OF CANTEEN TABLE | Annexure-J |
| XI | APPLICATION FORM | Annexure-K |
| XII | DECLARATION BY SUPPLIER | Annexure-L |
| XIII | FORMAT FOR THE SUBMISSION OF RATES – PRICE BID | Annexure-M |
| XIV | CHECK LIST | Annexure-N |

GUIDELINES FOR PREPARATION OF TENDER

1. **If the tenderer want to submit tender for more than one item, they must submit separate tender for each item complete in all respects. If the tenderer submits tender for more than one item in a single envelope, the same will outrightly rejected.**
2. Separate Tender fee along with Separate Earnest Money Deposit (EMD) and all other necessary documents should be submitted for each item. The main envelop should superscribe: "***Tender for _____, Last date of submission June 26, 2015; 11:00 A.M.***".
3. The proposals shall be submitted in two parts, viz. **Technical bid and Financial bid** in two separate sealed envelopes (with respective marking super-scribed in bold).
4. The first envelope (envelope 1) marked "**Technical bid**" should include the technical specifications and all eligibility documents. The first envelope should not contain any cost information whatsoever. This document should also have tender fee and EMD and all other document except financial bid.
5. The second envelope (envelope 2) marked "**Financial bid**" should contain the detailed price offer in prescribed format.
6. Envelop 3: Both the sealed envelopes Technical bid and financial bid should be placed in a bigger sealed envelope. The top of envelope must also contain Name of item applied, Name and Address of the tenderer, telephone and other contact details for further correspondence.
7. Technical compliance sheet and Financial bid for each item should be strictly as per tender format, and signed on each page.
8. Blank Tender Forms for the above items along with details can be downloaded from www.cup.ac.in or www.cup.edu.in. The non-refundable application fee must be accompanied with tender.
9. Tenders must accompany a copy of the "**General Financial Terms and Conditions**" section of this document, signed and stamped on each page indicating that they agree to these.
10. Last date of submission of tender along with requisite fee, EMD and all documents is June 26, 2015.
11. The DD for application fee, EMD or any other must be drawn in favour of "Central University of Punjab, Bathinda".
12. The tenderer must give certificate duly signed and stamped for the availability of spares and servicing of item within the specified periods as and when ordered.
13. Apart from all these terms and conditions, specific terms as specified for item must also be complied.
14. Colour of the items will be as per instructions of the University.

GENERAL FINANCIAL TERMS AND OTHER CONDITIONS

1. a). The bidders should have minimum three years' experience and technical capacity of the item bid for. Documents in its support be enclosed.

b). The bidders should have average turnover of 20 Lacs/ annum in the related business during the last three years. Trading Account & Balance Sheet for the same should be enclosed.
2. **Prices:** Quoted prices should be firm and FOR Central University of Punjab (CUPB), City Campus, Mansa Road, Bathinda and complete break up of all taxes and duties payable by the university should be clearly defined otherwise it will be presumed that the rates quoted are inclusive of all these charges and nothing extra will be paid. **Special Discount/ Rebates, whichever applicable to an educational Institution, may also be specifically indicated.**
3. **Payment terms:**
 - a) Letter of credit- 90% payment will be made through ILC and balance 10% after successful installation of the items and submission of performance bank guarantee for 5% of order value for warranty period + 3 months,
 - b) Or 100% payment will be made through RTGS/by cheque after delivery, installation and demonstration of goods in good condition and satisfactory inspection report of the Indenter and submission of performance bank guarantee for 5% of order value for warranty period + 3 months. **Firm must provide RTGS details.**
4. **Taxes:** All kinds of Statutory Taxes will be paid by the purchaser on the basis of supportive Documentary Evidence.
5. **Validity:** Tenders/Quotations should be valid for three months from the last date of its submission.
6. **Opening of Tenders:** Tenders complete in all respect will only be considered. Tenders/Quotations will be opened at the University campus as per given schedule, if the Tender opening day happens to be official Holiday then the tenders will be opened on the next working day, in the presence of bidders or their authorized representative whosoever may wish to be present.
7. **Incomplete or Misleading Tenders / Quotations:** Tenders/Quotations received late or incomplete in any respect/ misleading without earnest money& without required documents will be out rightly rejected.
8. **Right to reject:** The CUPB reserves right to accept/reject any or all the Tenders/Quotations at any time without assigning any reason.
9. **Delivery Schedule:** 21 days from the date of issue of supply order.
10. **Installations:** Installations of the item/systems under purchase will be of free of cost.
11. **Penalty for non/late delivery of material:** If the supplier fails to deliver the material/item within the stipulated delivery period of the Supply/Purchase order/contract the same is liable to pay penalty charges at 0.5% of the cost of undelivered goods/ services per week, not exceeding maximum limit of 10% of the cost of complete unit of undelivered item/material so delayed.

12. **Custom Duty & Excise Duty Exemption:** The University being a public funded and non-commercial research institution is exempted from paying Custom Duties vide notification no. 51/96-custom and the provision of the said notification will apply. University will provide DSIR certificate, Custom Duty Exemption Certificate (CDEC), road permit and other necessary certificates. Since the University does not have any Clearing Agent, the Supplier is requested to get the consignments cleared on behalf of the University. The admissible Custom Duty will be reimbursed to the Supplier on production of documentary evidence of payment of Custom Duty and also satisfactory installation report from the Indenter. The item should not be taken to warehouse/ Go-down and should come straight from the nearest Airport to the University. In case of inspection by the Custom, legible seal of Custom Officials should be present along the tearing of consignment.

13. **Security Deposit:**

a. You are required to submit within 30 days security deposit amounting to 5 per cent of ordered value either in demand draft in favour of the “Central University of Punjab, Bathinda” or in the form of Bank Guarantee (BG).

b. On faithful execution of the Supply/Work order/contract on all respects, including warranty period, the security deposit of the contractors/supplier shall be released.

c. In the event of default on your part in faithful execution of Supply/Work order/contract, the security deposit shall be forfeited by an order of the Registrar of the University. The forfeiture of security deposit shall be without prejudice to any other right arising or accruing to the university under relevant provisions of the Supply/Work Order/contract like penalty/damages for delay in delivery provisions under Negligence& default clause including suspension of business dealings with the university for a specific period.

14. **Warranty/ Guarantee:**

a) The supplier/contractor shall be responsible to replace free of cost with no transportation and insurance expenses to the University up to the destination of material/ item, the whole or any part of the material which under normal and proper use and maintenance, proves defective in material or workmanship within 18 months from the date, it is taken over by the University or 12 months from the date of installation whichever expires earlier, provided the University gives prompt written notice of such defects to the supplier/contractor. Such replacement shall be effected by the supplier/contractor within a reasonable time not exceeding 6 months of the intimation of defects. Supplier's/Contractor responsibility arising out of supply of material or its use whether on warranties or otherwise shall not in any case exceed the cost of correcting the defects or replacing the defective part/material and upon the expiry of the warranty period stipulated above, all such liabilities shall terminate.

b) The above provision shall equally apply to the material so replaced/repared by the Supplier/Contractor under this clause in case the same is again found to be defective within 12 months of the replacement/repair.

c) In case the replacement /repair of defective material is not carried out within six months of intimation of defects, the Supplier/Contractor shall have to pay interest @ 12 per cent per annum on the value of each complete operational unit of item beginning from the date of becoming defective up to date of its re-commissioning after replacement/repair.

15. **Civil Suit Jurisdiction:** All legal proceedings in connection with this Supply/Purchase order/Contract shall be subject to the territorial jurisdiction of the local Civil Courts, as per Indian Laws, at Bathinda only.

16. **Cancellation :** The University reserves the right to cancel the Supply/purchase order as a whole or in part at any time or in the event of default on the part of the Supplier prior to the receipt of information regarding taking in hand of the manufacture of material against the Supply/Purchase order/dispatch of material to the consignee.

17. Conditional bids shall not be considered.

18. The CUPB reserves the right to increase or decrease the quantity of the tender items.

TECHNICAL SPECIFICATIONS AND COMPLIANCE SHEET FOR BED

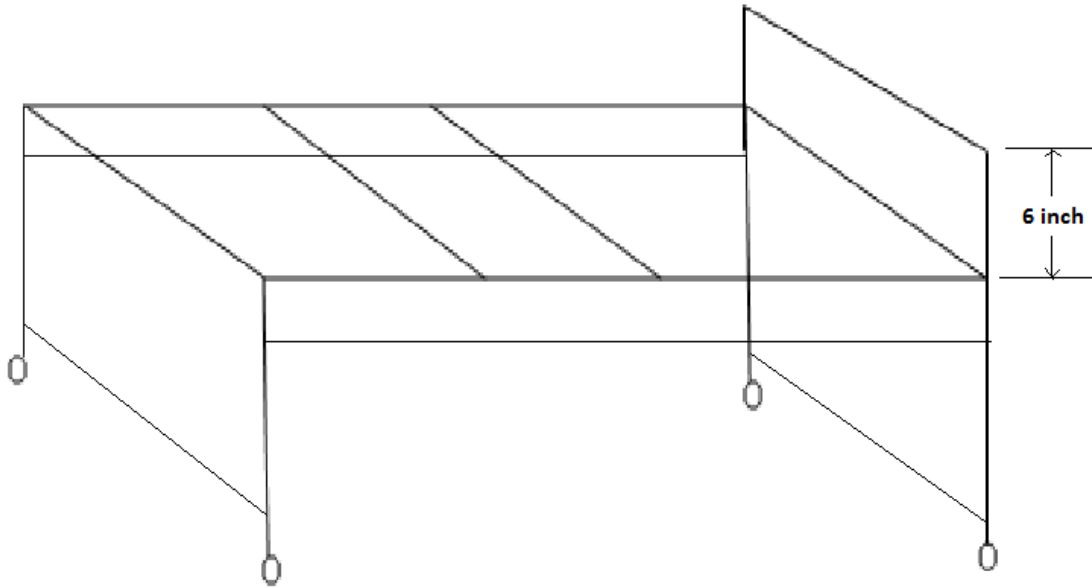

1. BODY Size: 6'x3'(LxW) With Standard Height and 50 mm X 25 mm Rectangular Pipe.
2. Pipe Thickness : 1.25 mm.
3. Supporting of Bed: Support to Legs: 25 mm Square Pipe on all side and 2 Middle Strength 1.25 mm thickness as per diagram.
4. PLY: 12 mm Thick Water Proof ply board (WBC) with ISI standard of Branded Company.
5. SHOE: PVC 100% Virgin Quality.
6. Paint: MS Structure should be painted with good quality Iron Red Oxide followed by double coat of paint.
7. Screw: Good Quality.
8. Frame should be welded by electric welding.
9. One Year Manufacturing Warranty.

TECHNICAL SPECIFICATIONS AND COMPLIANCE SHEET FOR CHAIR

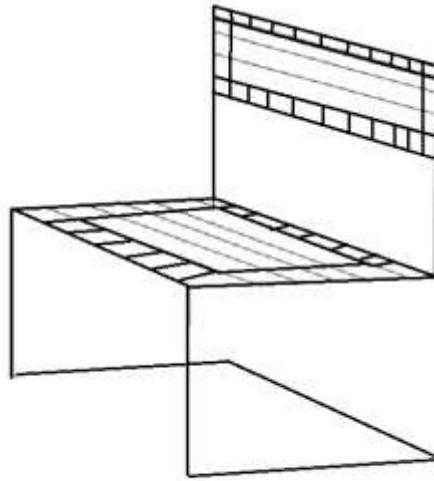

1. Body: 25 mm Tubular Pipe CRCA Pipe.
2. Seat & Back: Made Of Teakwood Frame thickness 25mm with High Class Spirit Polish & Caning With 100% Virgin Strip on Seat & Back.
3. Paint: Powder Coated with High Class Finish on all CRCA pipe.
4. Shoe: PVC Shoe on Foot for Protection of Iron & Colour of 100% virgin quality.
5. One Year Warranty.

TECHNICAL SPECIFICATIONS AND COMPLIANCE SHEET FOR STUDY TABLE

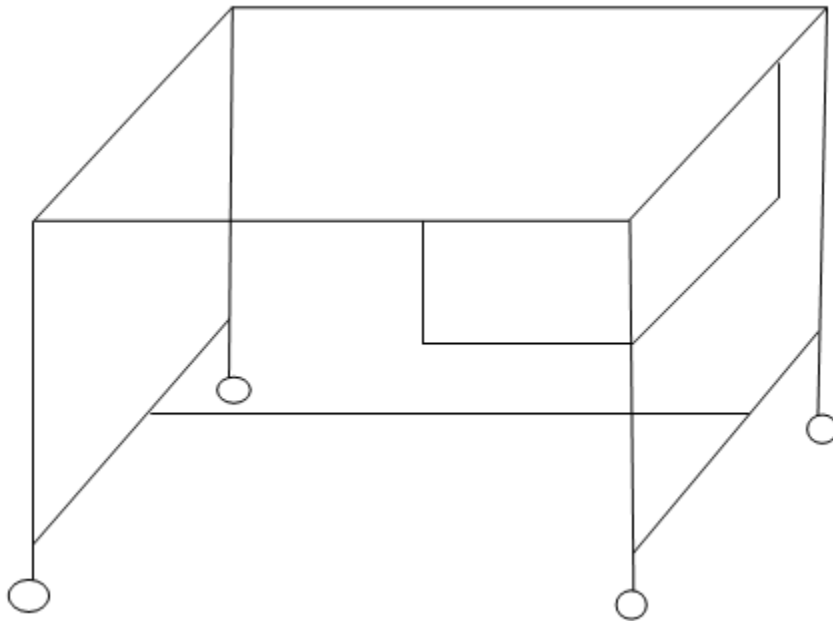

1. Size: 900x 750 mm with Standard height.
2. Drawer size: 350x 550x 152 mm.(0.80 mm CRCA sheet with lock of good quality)
3. Body: 32mm square Pipe of 1.4 mm thickness and powder coated.
4. Body Top: 25 mm PLPB (Pre Laminated Particle board of Asis/ Green lam/ Wintuf/ equivalent) with 2 mm thick Edge Binding and liping on edges.
5. Shoe: Heavy 100% Virgin Quality.
6. Frame should be welded by electric welding.
7. One year warranty for Lock and Paint.

TECHNICAL SPECIFICATIONS AND COMPLIANCE SHEET FOR STEEL ALMIRAH

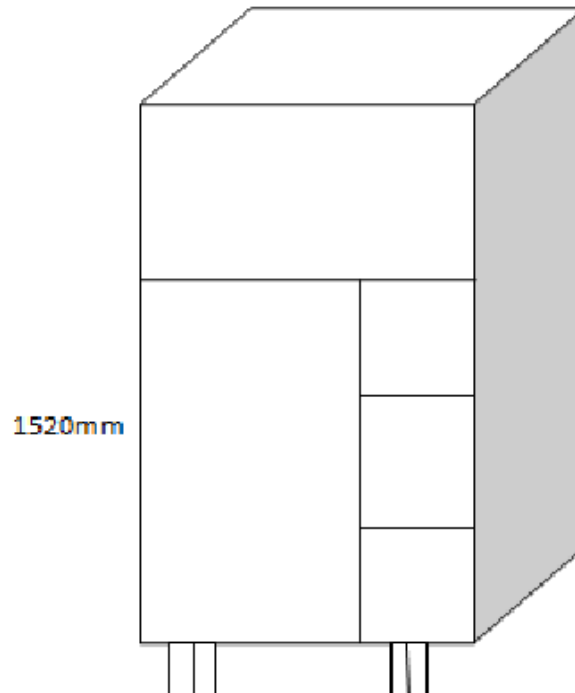

1. Size: 60x36x22 (HxWxD in inches).
2. Made of 0.80mm thick CRCA sheet with stifner at all shelves.
3. Doors and Foot 1mm thick CRCA sheet with spot welding without riveting.
4. Door locked with one Handle & Lock (Good quality Zinc plated lock).
5. Paint finishing: one coat of Red Oxide primer and Two coat of paint enamel with well finishing.
6. One year warranty.

TECHNICAL SPECIFICATIONS AND COMPLIANCE SHEET FOR MATTRESSES

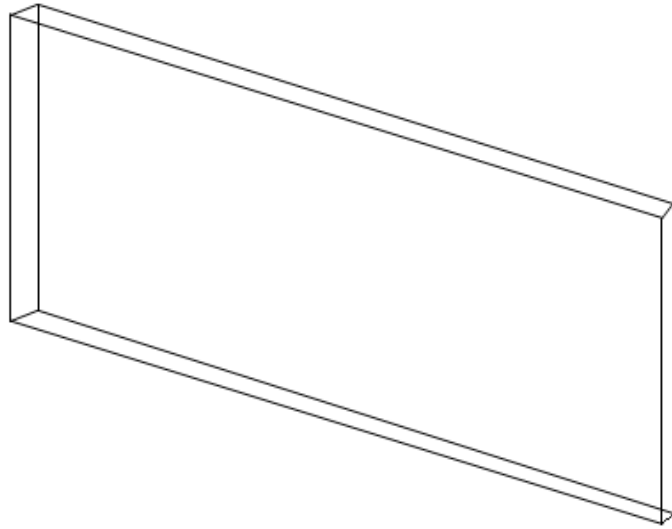

1. Dimensions: 1800 X 900 X 100 mm.
2. Made Of 32 mm Density Branded Foam of ISI mark Covered With Good Quality Cloth and Quilt Layer.
3. Five year warranty.

TECHNICAL SPECIFICATIONS AND COMPLIANCE SHEET FOR BOOK RACKS



1. Size: 36x15x15 (LXDXH inch)
2. Body : 1 mm thick body CRCA.
3. Slider Door of grinded glass (4mm) thickness.
4. Hang: It should be hangable by screws.
5. Paint: One redoxide coat and two enamel coat of branded quality.
6. One year warranty.
7. Installation is by Vendor at site.

TECHNICAL SPECIFICATIONS AND COMPLIANCE SHEET FOR CANTEEN CHAIR

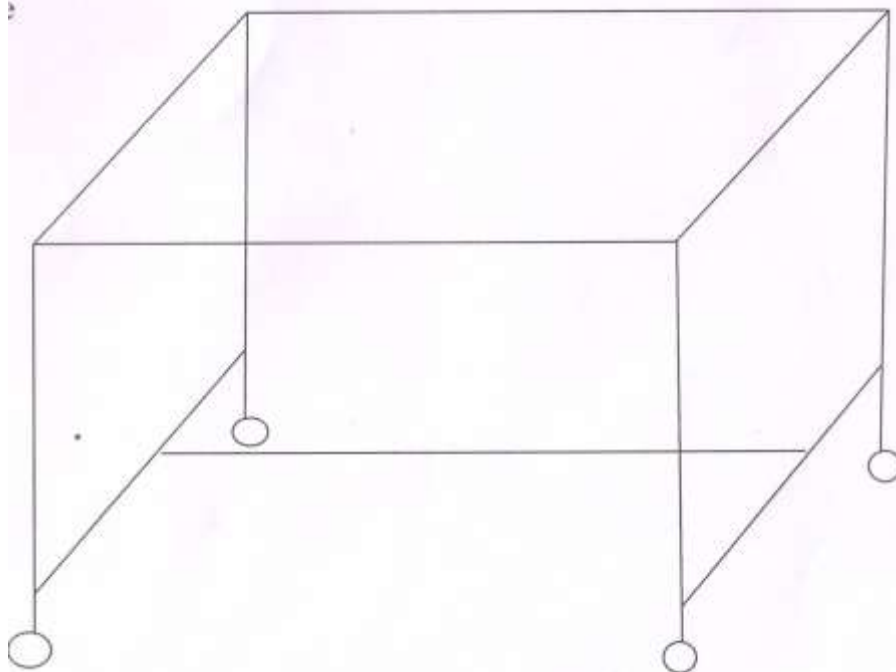

1. Stainless Steel pipe frame of 16 gauge thickness and 18mm circumference.
2. Seat of the Chair: Ballowal/ 100% Virgin equivalent Quality PVC.
3. PVC shoe at four legs 100% virgin quality.
4. Frame should be welded by electric welding.
5. Warranty: one year warranty.
6. PVC seat should be assembled on frame by steel screw.

TECHNICAL SPECIFICATIONS AND COMPLIANCE SHEET FOR CANTEEN TABLE

1. Table size= 48"x 30"x 30" or standard height with granite top and pipe frame.
2. Pipe frame: 38mm square pipe of 1.6mm thickness and pipe frame should be powder coated. Frame should be welded by electric welding.
3. Top of the Table: Granite 16mm of good quality. Finishing of the top: glossy black. Top granite should be fixed with frame of the table through pasting of 5mm thick rubber. Granite top should be round on all sides.
4. Frame should be welded by electric welding.
5. Warranty: One Year.
6. Legs of the frame should be covered with PVC shoes (100% virgin quality) upto 10cm height.

APPLICATION FORM

To be Filled Completely and Signed

1. Contact details of the head office of proposing firm:
 - a. Name-
 - b. Address-
 - c. Tel. No.-
 - d. Fax -
 - e. Email -
 - f. Web site (If any)

2. Name and full address of local office of proposing firm nearest to Bathinda:
 - a. Name-
 - b. Address-
 - c. Tel. No.-
 - d. Fax -
 - e. Email -
 - f. Web site (If any)

3. Name and full address of manufacturer:
 - a. Name-
 - b. Address-
 - c. Tel. No.-
 - d. Fax -
 - e. Email -
 - f. Web site (If any)

4. Name of advising bank and account number:

5. SWIFT Code:

6. PAN and TAN Number:

7. Manufacturing type (tick mark):
 - i. Imported
 - ii. Indigenous
 - iii. Both

8. Country(s) of origin:

9. Any other relevant information:

DECLARATION BY SUPPLIER

“It is certified that I/we have carefully read and understood the entire general, special as well as specific terms and conditions of these documents and agree to abide by all of these. All the information and commitments provided with the quotations are truthful and binding on the firm.”

Place:

Signature of Authorized Person

Date:

Designation

Seal

FORMAT FOR THE SUBMISSION OF RATES – PRICE BID

(To be submitted on the letterhead of the company/firm and put it in Envelope 2)

Item Price:

Name of the Item _____

Name of the Manufacturer _____

Make of the Item _____

| Sl. No. | Particulars | Rate/Unit |
|---------|--|-----------|
| 1 | Cost of the item (FOR Central University of Punjab, Bathinda). | |
| 2 | (___% of VAT/TAXES) | |
| 3 | Total (1+2) | |

Note: Taxes and other levies, if any are to be clearly specified in the bid.

This is certified that the rates quoted above are not more than the rates charged from any other Institution/Department/Organization.

Place:**Signature of Authorized Person****Date:****Designation****Seal**

CHECK LIST

(TO BE FILLED COMPLETELY & PLACED IN ENVELOPE-1)

| Sr. No. | Points to be verified | Yes/ No |
|----------------|--|----------------|
| 1 | Manufacturer Registration certificate issued by State/Central/ UT Govt. agency. In case of Dealer of well-known branded Manufacturer (Authorization certificate from Manufacturer in favor of dealer and manufacturer's registration certificate) | |
| 2 | Technical specification compliance sheet | |
| 3 | EMD | |
| 4 | Tender Fee | |
| 5 | Photocopy of PAN and TAN card | |
| 6 | User list and certificates issued by clients for the item bid for (if any) | |
| 7 | Copy of income tax return certificate | |
| 8 | Trading account and balance sheet of last 3 years (turnover of average of Rs. 20 lakh/annum for last 3 years) | |
| 9 | All other certificates as asked for in tender document a) Spare part availability certificate b) Certificate indicating country of manufacture c) Sales tax registration certificate Copy of "Eligibility Criteria and General Terms and Conditions" signed and stamped on each page | |

Place:**Signature of Authorized Person****Date:****Designation****Seal**